

Write your name here

Surname

Other names

**Pearson Edexcel Certificate**  
**Pearson Edexcel**  
**International GCSE**

Centre Number

--	--	--	--	--

Candidate Number

--	--	--	--	--

# Mathematics A

## Paper 2F



**Foundation Tier**

Thursday 8 June 2017 – Morning  
**Time: 2 hours**

Paper Reference  
**4MA0/2F**  
**KMA0/2F**

**You must have:**

Ruler graduated in centimetres and millimetres, protractor, compasses, pen, HB pencil, eraser, calculator. Tracing paper may be used.

Total Marks

### Instructions

- Use **black** ink or ball-point pen.
- **Fill in the boxes** at the top of this page with your name, centre number and candidate number.
- Answer **all** questions.
- Without sufficient working, correct answers may be awarded no marks.
- Answer the questions in the spaces provided  
– *there may be more space than you need.*
- **Calculators may be used.**
- You must **NOT** write anything on the formulae page.  
Anything you write on the formulae page will gain NO credit.

### Information

- The total mark for this paper is 100.
- The marks for **each** question are shown in brackets  
– *use this as a guide as to how much time to spend on each question.*

### Advice

- Read each question carefully before you start to answer it.
- Check your answers if you have time at the end.

Turn over ►

P48485A

©2017 Pearson Education Ltd.

1/1/1



Pearson

**International GCSE MATHEMATICS**  
**FORMULAE SHEET – FOUNDATION TIER**

Pythagoras' Theorem  
 $a^2 + b^2 = c^2$

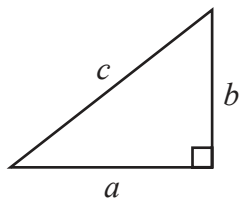

Area of a trapezium =  $\frac{1}{2}(a + b)h$

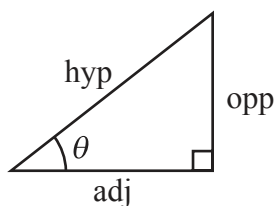
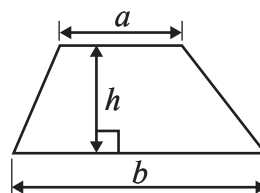

adj = hyp  $\times$  cos  $\theta$   
 opp = hyp  $\times$  sin  $\theta$   
 opp = adj  $\times$  tan  $\theta$

Volume of prism = area of cross section  $\times$  length

or  $\sin \theta = \frac{\text{opp}}{\text{hyp}}$

$\cos \theta = \frac{\text{adj}}{\text{hyp}}$

$\tan \theta = \frac{\text{opp}}{\text{adj}}$

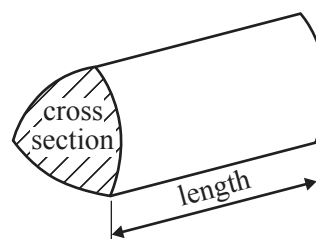

Circumference of circle =  $2\pi r$

Area of circle =  $\pi r^2$

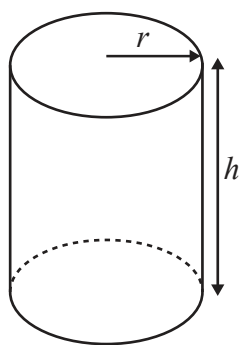

Volume of cylinder =  $\pi r^2 h$

Curved surface area of cylinder =  $2\pi r h$

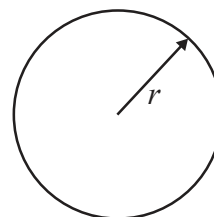

DO NOT WRITE IN THIS AREA

DO NOT WRITE IN THIS AREA

DO NOT WRITE IN THIS AREA



DO NOT WRITE IN THIS AREA

DO NOT WRITE IN THIS AREA

DO NOT WRITE IN THIS AREA

Answer ALL TWENTY THREE questions.

Write your answers in the spaces provided.

You must write down all the stages in your working.

- 1 (a) Write these numbers in order of size.  
Start with the smallest number.

-4      7      -1      3      -8

.....  
(1)

- (b) Write these numbers in order of size.  
Start with the smallest number.

0.078      0.4      0.407      0.8      0.007

.....  
(1)

- (c) Write  $\frac{3}{5}$  as a decimal.

.....  
(1)

- (d) Write 0.9 as a percentage.

..... %  
(1)

- (e) Find the number that is exactly halfway between 0.3 and 0.4

.....  
(1)

(Total for Question 1 is 5 marks)



- 2 (a) Write down the mathematical name of this 3-D shape.

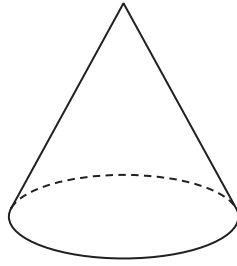

.....  
(1)

- (b) (i) Write down the mathematical name of this 3-D shape.

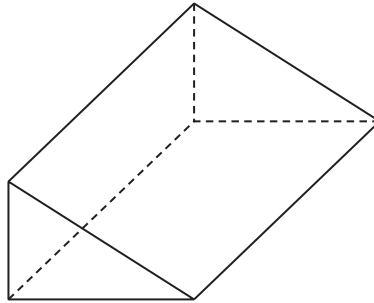

- (ii) How many vertices does this shape have?

- (iii) How many edges does this shape have?

.....  
(3)

The diagram shows a solid prism made from centimetre cubes.

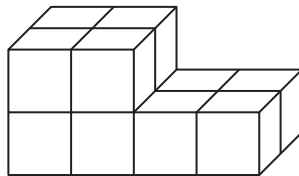

Diagram **NOT**  
accurately drawn

- (c) Find the volume of the prism.  
Give the units of your answer.

.....  
(3)

(Total for Question 2 is 7 marks)



DO NOT WRITE IN THIS AREA

DO NOT WRITE IN THIS AREA

DO NOT WRITE IN THIS AREA

3 The pictogram shows information about the number of goals scored by each of five netball teams on Saturday.

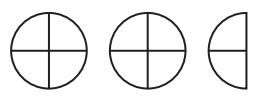
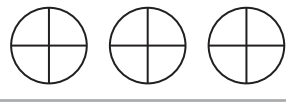
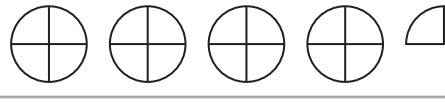
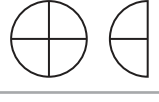
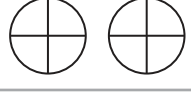
Oakley	
Jets	
Blues	
Reds	
Newtown	

(a) Which team scored the greatest number of goals on Saturday?

.....  
(1)

On Saturday, the number of goals scored by one of the teams was twice the number of goals scored by Reds.

(b) Which team?

.....  
(1)

Newtown scored 8 goals on Saturday.

(c) (i) How many goals did Jets score on Saturday?

.....

(ii) How many goals did Oakley score on Saturday?

.....  
(3)

(Total for Question 3 is 5 marks)



4 (a) Write down the mathematical name of a polygon with 5 sides.

(1)

(b) On the diagram, mark with arrows ( $>>$ ) a pair of parallel lines.

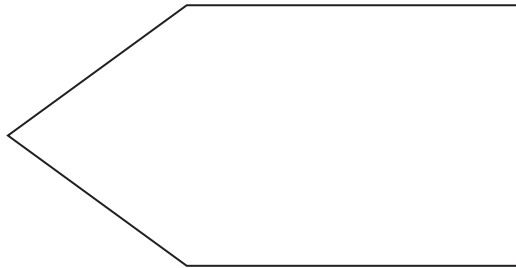

(1)

(c) On the grid below, draw a triangle that is congruent to the shaded triangle.

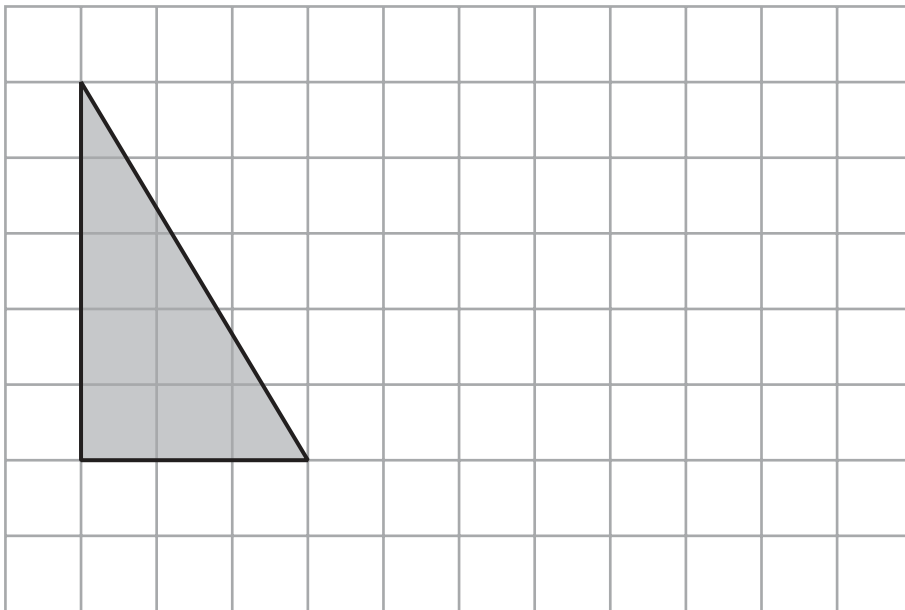

(1)

(Total for Question 4 is 3 marks)



DO NOT WRITE IN THIS AREA

DO NOT WRITE IN THIS AREA

DO NOT WRITE IN THIS AREA

5 Lesley buys

3 notebooks at \$1.59 each

2 pens at \$0.85 each

5 pencils at \$0.45 each

She pays with a \$20 note.

(a) How much change should Lesley get?

\$ .....  
(3)

Pritam has \$50 to spend on glasses.

Each glass costs \$2.40

He buys as many glasses as he can.

(b) How many glasses does Pritam buy?

.....  
(2)

(Total for Question 5 is 5 marks)

6 (a) Change 4.5 metres into centimetres.

..... centimetres  
(1)

(b) Change 8900 grams into kilograms.

..... kilograms  
(1)

(Total for Question 6 is 2 marks)



7 (a) Which one of these fractions is equivalent to  $\frac{2}{3}$ ?

$$\frac{9}{15} \quad \frac{10}{12} \quad \frac{8}{9} \quad \frac{12}{18} \quad \frac{20}{24}$$

.....  
(1)

(b) Work out  $\frac{3}{7}$  of 840 kg.

..... kg  
(2)

There are 240 cars in a car park.  
96 of these cars are red.

(c) What fraction of the cars in the car park are red?  
Give your fraction in its simplest form.

.....  
(2)

$\frac{2}{9}$  of a number is 8

(d) What is the number?

.....  
(2)

(Total for Question 7 is 7 marks)





impossible	unlikely	evens	likely	certain
------------	----------	-------	--------	---------

(a) Write down a word from the box that best describes the likelihood of each outcome.

(i) A person chosen at random will have their birthday on 29 February.

.....

(ii) The next baby born will be a girl.

.....

(2)

In a fridge, there are

4 strawberry yoghurts

2 peach yoghurts

5 cherry yoghurts

1 banana yoghurt

Sarah takes at random one of these yoghurts.

(b) Write down the probability that she takes

(i) a banana yoghurt,

.....

(ii) a strawberry yoghurt or a cherry yoghurt,

.....

(iii) a raspberry yoghurt.

.....

(3)

**(Total for Question 8 is 5 marks)**



9 This rule can be used to work out the cost, in pounds (£), of a taxi journey.

Multiply the number of kilometres of the taxi journey by 0.6 and then add 1.45

(a) Work out the cost of a taxi journey of 12 km.

£ .....  
(2)

The cost of a taxi journey was £13.45

(b) Work out the distance travelled by the taxi on this journey.

..... km  
(3)

(Total for Question 9 is 5 marks)

10

Diagram **NOT**  
accurately drawn

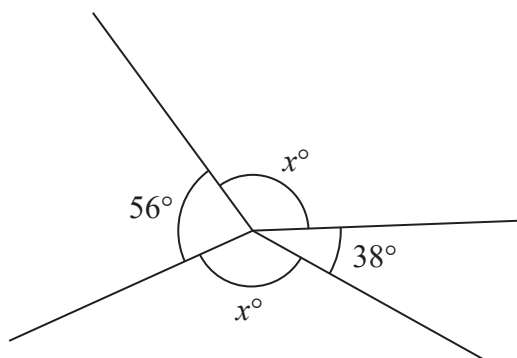

Work out the value of  $x$ .

.....

(Total for Question 10 is 3 marks)



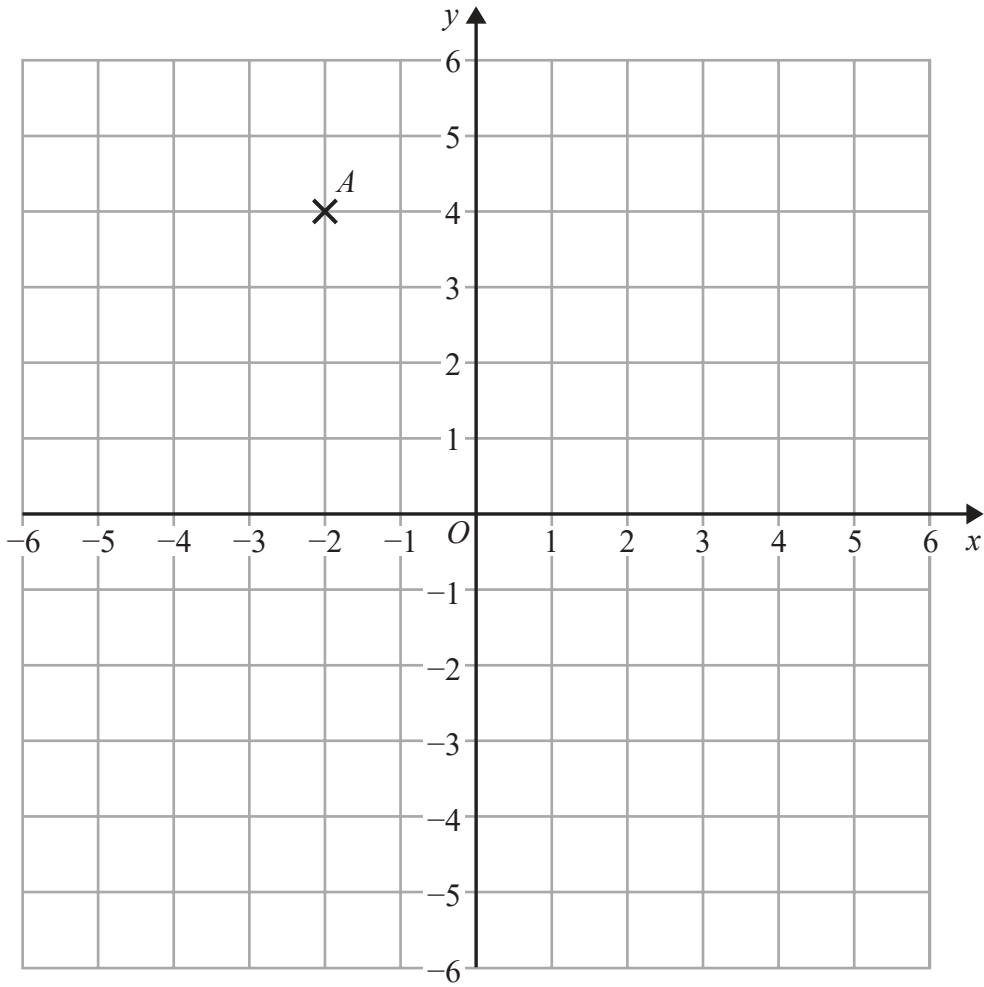

(a) Write down the coordinates of point *A*.

(....., .....)  
(1)

(b) Plot the point  $(-4, -3)$   
Label your point *B*.

(1)

(c) On the grid, draw the line with equation  $x = 3$

(1)

**(Total for Question 11 is 3 marks)**

DO NOT WRITE IN THIS AREA

DO NOT WRITE IN THIS AREA

DO NOT WRITE IN THIS AREA



12

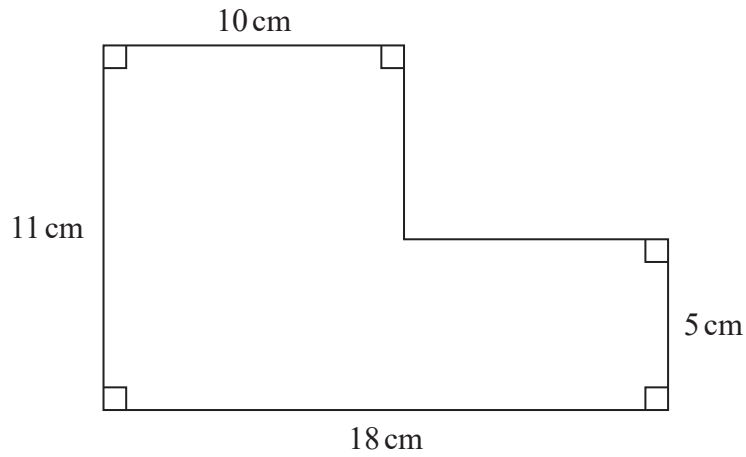

Diagram **NOT** accurately drawn

(a) Work out the area of the shape.

..... cm<sup>2</sup>  
(3)

A cuboid has a volume of 360 cm<sup>3</sup>.  
The cuboid has length 9 cm and width 5 cm.

(b) Work out the height of the cuboid.

..... cm  
(3)

(Total for Question 12 is 6 marks)

DO NOT WRITE IN THIS AREA

DO NOT WRITE IN THIS AREA

DO NOT WRITE IN THIS AREA



DO NOT WRITE IN THIS AREA

DO NOT WRITE IN THIS AREA

DO NOT WRITE IN THIS AREA

13 240 people were asked why they had come to Dubai.  
The pie chart gives information about their answers.

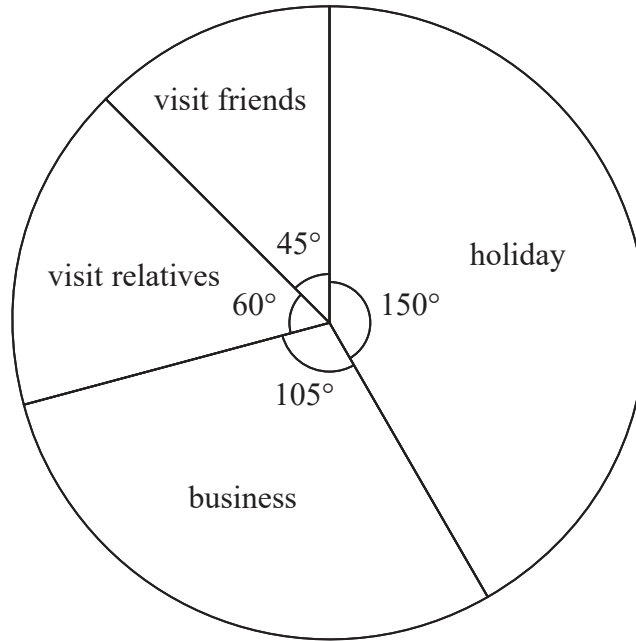

(a) How many of these people had come to Dubai on business?

.....  
(2)

Tavish asked 300 people at an airport in Sri Lanka why they had come to Sri Lanka.  
He is going to draw a pie chart for his results.

120 of the 300 people said that they had come to Sri Lanka for a holiday.  
Tavish draws a sector on his pie chart for this information.

(b) Work out the size of the angle of this sector.

.....  
(2)

(Total for Question 13 is 4 marks)



14  $P = \{p, o, r, t, u, g, a, l\}$   
 $I = \{i, t, a, l, y\}$

(a) List the members of the set

(i)  $P \cap I$

.....

(ii)  $P \cup I$

.....

(2)

$F = \{f, r, a, n, c, e\}$

(b) Is it true that  $I \cap F = \emptyset$ ?

Tick (✓) the appropriate box.

Yes

No

Explain your answer.

.....

(1)

(Total for Question 14 is 3 marks)



DO NOT WRITE IN THIS AREA

DO NOT WRITE IN THIS AREA

DO NOT WRITE IN THIS AREA

15  $M = 2t^2 - 7t$

(a) Work out the value of  $M$  when  $t = -3$

$M = \dots\dots\dots$   
(2)

(b) Solve  $4(x + 3) = 9x - 10$   
Show clear algebraic working.

$x = \dots\dots\dots$   
(3)

$y$  is an integer.  
 $-2 < y \leq 3$

(c) Write down all the possible values of  $y$ .

$\dots\dots\dots$   
(2)

**(Total for Question 15 is 7 marks)**



16 Lyn went on holiday to India.  
She changed £250 into rupees.

The exchange rate was £1 = 97 rupees.

(a) How many rupees did Lyn get?

..... rupees  
(2)

When she returns from holiday, Lyn has **four** 500 rupee notes.  
She changes this money into pounds.

The exchange rate is now £1 = 93.5 rupees.

(b) Work out how many pounds Lyn gets.  
Give your answer to the nearest pound.

£ .....  
(3)

(Total for Question 16 is 5 marks)

17 Point *A* has coordinates (-4, 9)  
Point *B* has coordinates (1, 5)

Find the coordinates of the midpoint of *AB*.

(..... , .....)

(Total for Question 17 is 2 marks)





DO NOT WRITE IN THIS AREA

DO NOT WRITE IN THIS AREA

DO NOT WRITE IN THIS AREA

18 Each time Astrid plays a game of chess against her computer, she will win or draw or lose.

For each game of chess

the probability that she will win is 0.3

the probability that she will lose is three times the probability that she will draw.

On Monday, Astrid is going to play 20 games of chess against her computer.

(a) Work out an estimate for the number of games of chess Astrid wins on Monday.

.....  
(2)

On Tuesday, Astrid plays a game of chess against her computer.

(b) Work out the probability that she will lose.

.....  
(3)

**(Total for Question 18 is 5 marks)**

19 There are 6 batteries in a small packet of batteries.

There are 9 batteries in a large packet of batteries.

Chow buys  $m$  small packets of batteries and  $g$  large packets of batteries.

The total number of batteries Chow buys is  $T$ .

Write down a formula, in terms of  $m$  and  $g$ , for  $T$ .

.....

**(Total for Question 19 is 3 marks)**



20 (a) Show that  $\frac{7}{12} + \frac{3}{8} = \frac{23}{24}$

(2)

(b) Show that  $1\frac{2}{3} \times 2\frac{1}{15} = 3\frac{4}{9}$

(3)

(Total for Question 20 is 5 marks)

DO NOT WRITE IN THIS AREA

DO NOT WRITE IN THIS AREA

DO NOT WRITE IN THIS AREA



DO NOT WRITE IN THIS AREA

DO NOT WRITE IN THIS AREA

DO NOT WRITE IN THIS AREA

21 Each interior angle of a regular polygon is  $156^\circ$

Work out the number of sides of the polygon.

.....

**(Total for Question 21 is 3 marks)**

22 Manu, Liam and Ned share £420 in the ratios 4 : 5 : 3

Liam then gives Ned £75

Express the amount of money that Ned now has as a percentage of the £420

Give your answer correct to the nearest whole number.

..... %

**(Total for Question 22 is 4 marks)**



23 Solve  $x - 5y = 14$   
 $3x + 5y = 2$

Show clear algebraic working.

$x = \dots\dots\dots$

$y = \dots\dots\dots$

(Total for Question 23 is 3 marks)

---

**TOTAL FOR PAPER IS 100 MARKS**

DO NOT WRITE IN THIS AREA

DO NOT WRITE IN THIS AREA

DO NOT WRITE IN THIS AREA

